

Town of Cortland

Authorization to Bid Form

Addenda will be published to our Bid Letting page in the same manner as the plans and specifications. It is the sole responsibility of the plan holders to periodically check the website for plan addenda.

ALL CONTRACTORS PLANNING TO PLACE A BID MUST FILL OUT THIS FORM TO BE AUTHORIZED TO BID.

- This form must be completed, signed and either faxed to 815-756-4583 or emailed to engineer@cortlandil.org, at least 48 hours prior to the bid opening in order for your bid to be considered.
- Failure to submit this completed form will result in the bid not being accepted.

- The bid results are preliminary until approved by the Town Board.

Authorization to Bid Form	
Company Name:	
Street Address:	
City, State, Zip Code	
Phone:	
Fax:	
Email:	
Bid Letting Date:	

Projects Intending to Bid:

Section Number	Description

Completed by: _____
 Signature: _____
 Date: _____



COVER SHEET

Proposal Submitted By:
 Contractor's Name

 Contractor's Address _____ City _____ State _____ Zip Code _____

STATE OF ILLINOIS
 Local Public Agency _____ County DeKalb Section Number _____
 Town of Cortland

Route(s) (Street/Road Name) _____ Type of Funds Local
 East North Avenue

Proposal Only Proposal and Plans Proposal only, plans are separate

Submitted/Approved
For Local Public Agency:

For a County and Road District Project

Submitted/Approved
Highway Commissioner Signature & Date

Submitted/Approved
County Engineer/Superintendent of Highways Signature & Date

For a Municipal Project

Submitted/Approved **Passed**
 Signature & Date _____

 Official Title
 Town Engineer

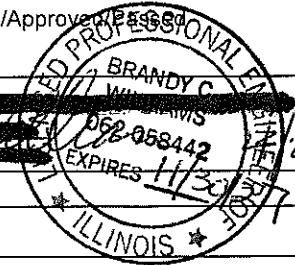

Department of Transportation

Released for bid based on limited review
 Regional Engineer Signature & Date

Note: All proposal documents, including Proposal Guaranty Checks or Proposal Bid Bonds, should be stapled together to prevent loss when bids are processed.

Local Public Agency	County	Section Number	Route(s) (Street/Road Name)
Town of Cortland	DeKalb		East North Avenue

NOTICE TO BIDDERS

Sealed proposals for the project described below will be received at the office of Town Hall
 Name of Office
59 S. Somonauk Road, PO Box 519, Cortland IL 60112-0519 until 1:30 PM on 05/13/26
 Address Time Date

Sealed proposals will be opened and read publicly at the office of Town Hall
 Name of Office
59 S. Somonauk Road, Cortland IL 60112 at 1:30 PM on 05/13/26
 Address Time Date

DESCRIPTION OF WORK

Location	Project Length
East North Avenue	3450 LF

Proposed Improvement
 HMA Surface Removal, HMA binder and surface courses and other incidental work.

1. Plans and proposal forms will be available in the office of
Town of Cortland website at <https://www.cortlandil.org/>
 All requirements listed must be followed including submission of the Authorization to Bid form 48 hours prior to the bid opening of the bids to be eligible to be opened and read.

2. Prequalification
 If checked, the 2 apparent as read low bidders must file within 24 hours after the letting an "Affidavit of Availability" (Form BC 57) in triplicate, showing all uncompleted contracts awarded to them and all low bids pending award for Federal, State, County, Municipal and private work. One original shall be filed with the Awarding Authority and two originals with the IDOT District Office.
3. The Awarding Authority reserves the right to waive technicalities and to reject any or all proposals as provided in BLRS Special Provision for Bidding Requirements and Conditions for Contract Proposals.
4. The following BLR Forms shall be returned by the bidder to the Awarding Authority:
 - a. Local Public Agency Formal Contract Proposal (BLR 12200)
 - b. Schedule of Prices (BLR 12201)
 - c. Proposal Bid Bond (BLR 12230) (if applicable)
 - d. Apprenticeship or Training Program Certification (BLR 12325) (do not use for project with Federal funds.)
 - e. Affidavit of Illinois Business Office (BLR 12326) (do not use for project with Federal funds)
5. The quantities appearing in the bid schedule are approximate and are prepared for the comparison of bids. Payment to the Contractor will be made only for the actual quantities of work performed and accepted or materials furnished according to the contract. The scheduled quantities of work to be done and materials to be furnished may be increased, decreased or omitted as hereinafter provided.
6. Submission of a bid shall be conclusive assurance and warranty the bidder has examined the plans and understands all requirements for the performance of work. The bidder will be responsible for all errors in the proposal resulting from failure or neglect to conduct an in depth examination. The Awarding Authority will, in no case, be responsible for any costs, expenses, losses or changes in anticipated profits resulting from such failure or neglect of the bidder.
7. The bidder shall take no advantage of any error or omission in the proposal and advertised contract.
8. If a special envelope is supplied by the Awarding Authority, each proposal should be submitted in that envelope furnished by the Awarding Agency and the blank spaces on the envelope shall be filled in correctly to clearly indicate its contents. When an envelope other than the special one furnished by the Awarding Authority is used, it shall be marked to clearly indicate its contents. When sent by mail, the sealed proposal shall be addressed to the Awarding Authority at the address and in care of the official in whose office the bids are to be received. All proposals shall be filed prior to the time and at the place specified in the Notice to Bidders. Proposals received after the time specified will be returned to the bidder unopened.
9. Permission will be given to a bidder to withdraw a proposal if the bidder makes the request in writing or in person before the time for opening proposals.

Local Public Agency	County	Section Number	Route(s) (Street/Road Name)
Town of Cortland	DeKalb		East North Avenue

PROPOSAL

1. Proposal of _____ Contractor's Name _____
 _____ Contractor's Address _____
2. The plans for the proposed work are those prepared by Town of Cortland
 and approved by the Department of Transportation on N/A
3. The specifications referred to herein are those prepared by the Department of Transportation and designated as "Standard Specifications for Road and Bridge Construction" and the " Supplemental Specifications and Recurring Special Provisions" thereto, adopted and in effect on the date of invitation for bids.
4. The undersigned agrees to accept, as part of the contract, the applicable Special Provisions indicated on the "Check Sheet for Recurring Special Provisions" contained in this proposal.
5. The undersigned agrees to complete the work within _____ working days or by 10/30/26 unless additional time is granted in accordance with the specifications.
6. The successful bidder at the time of execution of the contract will be required to deposit a contract bond for the full amount of the award. When a contract bond is not required, the proposal guaranty check will be held in lieu thereof. If this proposal is accepted and the undersigned fails to execute a contract and contract bond as required, it is hereby agreed that the Bid Bond of check shall be forfeited to the Awarding Authority.
7. Each pay item should have a unit price and a total price. If no total price is shown or if there is a discrepancy between the products of the unit price multiplied by the quantity, the unit price shall govern. If a unit price is omitted, the total price will be divided by the quantity in order to establish a unit price. A bid may be declared unacceptable if neither a unit price nor a total price is shown.
8. The undersigned submits herewith the schedule of prices on BLR 12201 covering the work to be performed under this contract.
9. The undersigned further agrees that if awarded the contract for the sections contained in the combinations on BLR 12201, the work shall be in accordance with the requirements of each individual proposal for the multiple bid specified in the Schedule for Multiple Bids below.
10. A proposal guaranty in the proper amount, as specified in BLRS Special Provision for Bidding Requirements and Conditions for Contract Proposals, will be required. Bid Bonds will be allowed as a proposal guaranty. Accompanying this proposal is either a bid bond, if allowed, on Department form BLR 12230 or a proposal guaranty check, complying with the specifications, made payable to: Town of Cortland Treasurer of _____
 The amount of the check is _____ (_____).

Attach Cashier's Check or Certified Check Here

In the event that one proposal guaranty check is intended to cover two or more bid proposals, the amount must be equal to the sum of the proposal guaranties which would be required for each individual bid proposal. If the proposal guaranty check is placed in another bid proposal, state below where it may be found.

The proposal guaranty check will be found in the bid proposal for: Section Number _____

Local Public Agency	County	Section Number	Route(s) (Street/Road Name)
Town of Cortland	DeKalb		East North Avenue

CONTRACTOR CERTIFICATIONS

The certifications hereinafter made by the bidder are each a material representation of fact upon which reliance is placed should the Department enter into the contract with the bidder.

1. **Debt Delinquency.** The bidder or contractor or subcontractor, respectively, certifies that it is not delinquent in the payment of any tax administered by the Department of Revenue unless the individual or other entity is contesting, in accordance with the procedure established by the appropriate Revenue Act, its liability for the tax or the amount of the tax. Making a false statement voids the contract and allows the Department to recover all amounts paid to the individual or entity under the contract in a civil action.
2. **Bid-Rigging or Bid Rotating.** The bidder or contractor or subcontractor, respectively, certifies that it is not barred from contracting with the Department by reason of a violation of either 720 ILCS 5/33E-3 or 720 ILCS 5/33E-4.

A violation of section 33E-3 would be represented by a conviction of the crime of bid-rigging which, in addition to Class 3 felony sentencing, provides that any person convicted of this offense, or any similar offense of any state or the United States which contains the same elements as this offense shall be barred for 5 years from the date of conviction from contracting with any unit of State or local government. No corporation shall be barred from contracting with any unit of State or local government as a result of a conviction under this Section of any employee or agent of such corporation if the employee so convicted is no longer employed by the corporation: (1) it has been finally adjudicated not guilty or (2) if it demonstrates to the governmental entity with which it seeks to contract that entity finds that the commission of the offense was neither authorized, requested, commanded, nor performed by a director, officer or a high managerial agent on behalf of the corporation.

A violation of Section 33E-4 would be represented by a conviction of the crime of bid-rotating which, in addition to Class 2 felony sentencing, provides that any person convicted of this offense or any similar offense of any state or the United States which contains the same elements as this offense shall be permanently barred from contracting with any unit of State of Local government. No corporation shall be barred from contracting with any unit of State or Local government as a result of a conviction under this Section of any employee or agent of such corporation if the employee so convicted is no longer employed by the corporation and: (1) it has been finally adjudicated not guilty or (2) if it demonstrates to the governmental entity with which it seeks to contract and that entity finds that the commission of the offense was neither authorized, requested, commanded, nor performed by a director, officer or a high managerial agent on behalf of the corporation.

3. **Bribery.** The bidder or contractor or subcontractor, respectively, certifies that, it has not been convicted of bribery or attempting to bribe an officer or employee of the State of Illinois or any unit of local government, nor has the firm made an admission of guilt of such conduct which is a matter of record, nor has an official, agent, or employee of the firm committed bribery or attempted bribery on behalf of the firm and pursuant to the direction or authorization of a responsible official of the firm.
4. **Interim Suspension or Suspension.** The bidder or contractor or subcontractor, respectively, certifies that it is not currently under a suspension as defined in Subpart I of Title 44 Subtitle A Chapter III Part 6 of the Illinois Administrative code. Furthermore, if suspended prior to completion of this work, the contract or contracts executed for the completion of this work may be canceled.

Attest:

Secretary

Secretary

Treasurer



Contractor's Name

Contractor's Address

City

State

Zip Code

Local Public Agency

County

Section Number

Route(s) (Street/Road Name)

Schedule for Multiple Bids

Combination Letter	Section Included in Combinations	Total

Schedule for Single Bid

(For complete information covering these items, see plans and specifications.)

Item Number	Items	Unit	Quantity	Unit Price	Total
40600275	BIT MATLS PR CT	LB	10782		
40600290	BIT MATLS TACK CT	LB	10782		
40600370	LONG JOINT SEALANT	FT	3450		
40600982	HMA SURF REM BUTT JT	SY	53		
40602978	HMA BC IL-9.5 N50	TN	773		
40604050	HMA SC IL-9.5 C N50	TN	773		
44000157	HMA SURF REM 2	SY	9200		
78001110	PAINT PVT MK LINE 4	FT	7760		
Bidder's Total Proposal					

1. Each pay item should have a unit price and a total price.
2. If no total price is shown or if there is a discrepancy between the product of the unit price multiplied by the quantity, the unit price shall govern.
3. If a unit price is omitted, the total price will be divided by the quantity in order to establish a unit price.
4. A bid may be declared unacceptable if neither a unit price or total price is shown.



Local Public Agency Proposal Bid Bond

Local Public Agency: Town of Cortland, County: DeKalb, Section Number: []

WE, [] as PRINCIPAL, and [] as SURETY, are held jointly, severally and firmly bound unto the above Local Public Agency (hereafter referred to as "LPA") in the penal sum of 5% of the total bid price, or for the amount specified in the proposal documents in effect on the date of invitation for bids, whichever is the lesser sum. We bind ourselves, our heirs, executors, administrators, successors, and assigns, jointly pay to the LPA this sum under the conditions of this instrument.

WHEREAS THE CONDITION OF THE FOREGOING OBLIGATION IS SUCH that, the said PRINCIPAL is submitting a written proposal to the LPA acting through its awarding authority for the construction of the work designated as the above section.

THEREFORE if the proposal is accepted and a contract awarded to the PRINCIPAL by the LPA for the above designated section and the PRINCIPAL shall within fifteen (15) days after award enter into a formal contract, furnish surety guaranteeing the faithful performance of the work, and furnish evidence of the required insurance coverage, all as provided in the "Standard Specifications for Road and Bridge Construction" and applicable Supplemental Specifications, then this obligation shall become void; otherwise it shall remain in full force and effect.

IN THE EVENT the LPA determines the PRINCIPAL has failed to enter into a formal contract in compliance with any requirements set forth in the preceding paragraph, then the LPA acting through its awarding authority shall immediately be entitled to recover the full penal sum set out above, together with all court costs, all attorney fees, and any other expense of recovery.

IN TESTIMONY WHEREOF, the said PRINCIPAL and the said SURETY have caused this instrument to be signed by their respective officers this [] Day of [] Month and Year

Principal

Company Name: []
Signature & Date: []
By: []
Title: []

Company Name: []
Signature & Date: []
By: []
Title: []

(If Principal is a joint venture of two or more contractors, the company names, and authorized signatures of each contractor must be affixed.)

Surety

Name of Surety: []

Signature of Attorney-in-Fact Signature & Date: []
By: []

STATE OF IL
COUNTY OF

I [] , a Notary Public in and for said county do hereby certify that

(Insert names of individuals signing on behalf of PRINCIPAL & SURETY)

who are each personally known to me to be the same persons whose names are subscribed to the foregoing instrument on behalf of PRINCIPAL and SURETY, appeared before me this day in person and acknowledged respectively, that they signed and delivered said instruments as their free and voluntary act for the uses and purposes therein set forth.

Given under my hand and notarial seal this [] day of [] Month and Year

(SEAL, if required by the LPA)

Notary Public Signature & Date: []

Date commission expires []

Local Public Agency

County

Section Number

Town of Cortland

DeKalb

ELECTRONIC BID BOND

Electronic bid bond is allowed (box must be checked by LPA if electronic bid bond is allowed)

The Principal may submit an electronic bid bond, in lieu of completing the above section of the Proposal Bid Bond Form. By providing an electronic bid bond ID code and signing below, the Principal is ensuring the identified electronic bid bond has been executed and the Principal and Surety are firmly bound unto the LPA under the conditions of the bid bond as shown above. (If PRINCIPAL is a joint venture of two or more contractors, an electronic bid bond ID code, company/Bidder name title and date must be affixed for each contractor in the venture.)

Electronic Bid Bond ID Code

--	--	--	--	--	--	--	--	--	--	--	--	--	--	--

Company/Bidder Name

--

Signature & Date

--

Title

--



Apprenticeship and Training Program Certification

Local Public Agency	County	Street Name/Road Name	Section Number
Town of Cortland	DeKalb	East North Avenue	

All contractors are required to complete the following certification

- For this contract proposal or for all bidding groups in this deliver and install proposal.
- For the following deliver and install bidding groups in this material proposal.

Illinois Department of Transportation policy, adopted in accordance with the provisions of the Illinois Highway Code, requires this contract to be awarded to the lowest responsive and responsible bidder. The award decision is subject to approval by the Department. In addition to all other responsibility factors, this contract or deliver and install proposal requires all bidders and all bidder's subcontractors to disclose participation in apprenticeship or training programs that are (1) approved by and registered with the United States Department of Labor's Bureau of Apprenticeship and Training, and (2) applicable to the work of the above indicated proposals or groups. Therefore, all bidders are required to complete the following certification:

1. Except as provided in paragraph 4 below, the undersigned bidder certifies that it is a participant, either as an individual or as part of a group program, in an approved apprenticeship or training program applicable to each type of work or craft that the bidder will perform with its own employees.
2. The undersigned bidder further certifies, for work to be performed by subcontract, that each of its subcontractors either (A) is, at the time of such bid, participating in an approved, applicable apprenticeship or training program; or (B) will, prior to commencement of performance of work pursuant to this contract, establish participation in an approved apprenticeship or training program applicable to the work of the subcontract.
3. The undersigned bidder, by inclusion in the list in the space below, certifies the official name of each program sponsor holding the Certificate of Registration for all of the types of work or crafts in which the bidder is a participant and that will be performed with the bidder's employees. Types of work or craft that will be subcontracted shall be included and listed as subcontract work. The list shall also indicate any type of work or craft job category for which there is no applicable apprenticeship or training program available.

4. Except for any work identified above, if any bidder or subcontractor shall perform all or part of the work of the contract or deliver and install proposal solely by individual owners, partners or members and not by employees to whom the payment of prevailing rates of wages would be required, check the following box, and identify the owner/operator workforces and positions of ownership.

The requirements of this certification and disclosure are a material part of the contract, and the contractor shall require this certification provision to be included in all approved subcontracts. The bidder is responsible for making a complete report and shall make certain that each type of work or craft job category that will be utilized on the project is accounted for and listed. The Department at any time before or afterward may require the production of a copy of each applicable Certificate of Registration issued by the United States Department of Labor evidencing such participation by the contractor and any or all of its subcontractors. In order to fulfill the participation requirement, it shall not be necessary that any applicable program sponsor be currently taking or that it will take applications for apprenticeship, training or employment during the performance of the work of this contract or deliver and install proposal.

Bidder	Signature & Date		
<div style="border: 1px solid black; height: 20px;"></div>	<div style="border: 1px solid black; height: 40px;"></div>		
Title			
<div style="border: 1px solid black; height: 20px;"></div>			
Address	City	State	Zip Code
<div style="border: 1px solid black; height: 20px;"></div>	<div style="border: 1px solid black; height: 20px;"></div>	<div style="border: 1px solid black; height: 20px;"></div>	<div style="border: 1px solid black; height: 20px;"></div>



Affidavit of Illinois Business Office

Local Public Agency	County	Street Name/Road Name	Section Number
Town of Cortland	DeKalb	East North Avenue	

I, _____ of _____, _____,
Name of Affiant City of Affiant State of Affiant

being first duly sworn upon oath, state as follows:

1. That I am the _____ of _____.
Officer or Position Bidder
2. That I have personal knowledge of the facts herein stated.
3. That, if selected under the proposal described above, _____, will maintain a business office in the
Bidder
 State of Illinois, which will be located in _____ County, Illinois.
County
4. That this business office will serve as the primary place of employment for any persons employed in the construction contemplated by this proposal.
5. That this Affidavit is given as a requirement of state law as provided in Section 30-22(8) of the Illinois Procurement Code.

Signature & Date

Print Name of Affiant

Notary Public

State of IL

County _____

Signed (or subscribed or attested) before me on _____ by
(date)

_____, authorized agent(s) of
(name/s of person/s)

Bidder

Notary Public Signature & Date

My commission expires _____

(SEAL)



Bureau of Construction
2300 South Dirksen Parkway/Room 322
Springfield, IL 62764

Instructions: Complete this form by either typing or using black ink. "Authorization to Bid" will not be issued unless both sides of this form are completed in detail. Use additional forms as needed to list all work.

Part I. Work Under Contract

List below all work you have under contract as either a prime contractor or a subcontractor. It is required to include all pending low bids not yet awarded or rejected. In a joint venture, list only that portion of the work which is the responsibility of your company. The uncompleted dollar value is to be based upon the most recent engineer's or owners estimate, and must include work subcontracted to others. If no work is contracted, show NONE.

	1	2	3	4	Awards Pending	Accumulated Totals
Contract Number						
Contract With						
Estimated Completion Date						
Total Contract Price						
Uncompleted Dollar Value if Firm is the Prime Contractor						
Uncompleted Dollar Value if Firm is the Subcontractor						
Total Value of All Work						

Part II. Awards Pending and Uncompleted Work to be done with your own forces.

List below the uncompleted dollar value of work for each contract and awards pending to be completed with your own forces. All work subcontracted to others will be listed on the reverse of this form. In a joint venture, list only that portion of the work to be done by your company. If no work is contracted, show NONE.

Earthwork						
Portland Cement Concrete Paving						
HMA Plant Mix						
HMA Paving						
Clean & Seal Cracks/Joints						
Aggregate Bases, Surfaces						
Highway, R.R., Waterway Struc.						
Drainage						
Electrical						
Cover and Seal Coats						
Concrete Construction						
Landscaping						
Fencing						
Guardrail						
Painting						
Signing						
Cold Milling, Planning, Rotomilling						
Demolition						
Pavement Markings (Paint)						
Other Construction (List)						
Totals						

Disclosure of this information is REQUIRED to accomplish the statutory purpose as outlined in the "Illinois Procurement Code." Failure to comply will result in non-issuance of an "Authorization To Bid." This form has been approved by the State Forms Management Center.

Part III. Work Subcontracted to Others.

For each contract described in Part I, list all the work you have subcontracted to others.

	1	2	3	4	Awards Pending
Subcontractor					
Type of Work					
Subcontract Price					
Amount Uncompleted					
Subcontractor					
Type of Work					
Subcontract Price					
Amount Uncompleted					
Subcontractor					
Type of Work					
Subcontract Price					
Amount Uncompleted					
Subcontractor					
Type of Work					
Subcontract Price					
Amount Uncompleted					
Subcontractor					
Type of Work					
Subcontract Price					
Amount Uncompleted					
Total Uncompleted					

Notary

I, being duly sworn, do hereby declare this affidavit is a true and correct statement relating to ALL uncompleted contracts of the undersigned for Federal, State, County, City and private work, including ALL subcontract work, ALL pending low bids not yet awarded or rejected and ALL estimated completion dates.

Officer or Director

Title

Signature

Date

Company

Address

City

State

Zip Code

Subscribed and sworn to before me

this _____ day of _____, _____

(Signature of Notary Public)

My commission expires _____

(Notary Seal)

Add pages for additional contracts



Bureau of Construction
2300 South Dirksen Parkway/Room 322
Springfield, IL 62764

Instructions: Complete this form by either typing or using black ink. "Authorization to Bid" will not be issued unless both sides of this form are completed in detail. Use additional forms as needed to list all work.

Part I. Work Under Contract

List below all work you have under contract as either a prime contractor or a subcontractor. It is required to include all pending low bids not yet awarded or rejected. In a joint venture, list only that portion of the work which is the responsibility of your company. The uncompleted dollar value is to be based upon the most recent engineer's or owners estimate, and must include work subcontracted to others. If no work is contracted, show NONE.

	1	2	3	4	Awards Pending	Accumulated Totals
Contract Number						
Contract With						
Estimated Completion Date						
Total Contract Price						
Uncompleted Dollar Value if Firm is the Prime Contractor						
Uncompleted Dollar Value if Firm is the Subcontractor						
Total Value of All Work						

Part II. Awards Pending and Uncompleted Work to be done with your own forces.

List below the uncompleted dollar value of work for each contract and awards pending to be completed with your own forces. All work subcontracted to others will be listed on the reverse of this form. In a joint venture, list only that portion of the work to be done by your company. If no work is contracted, show NONE.

Earthwork						
Portland Cement Concrete Paving						
HMA Plant Mix						
HMA Paving						
Clean & Seal Cracks/Joints						
Aggregate Bases, Surfaces						
Highway, R.R., Waterway Struc.						
Drainage						
Electrical						
Cover and Seal Coats						
Concrete Construction						
Landscaping						
Fencing						
Guardrail						
Painting						
Signing						
Cold Milling, Planning, Rotomilling						
Demolition						
Pavement Markings (Paint)						
Other Construction (List)						
Totals						

Disclosure of this information is REQUIRED to accomplish the statutory purpose as outlined in the "Illinois Procurement Code." Failure to comply will result in non-issuance of an "Authorization To Bid." This form has been approved by the State Forms Management Center.

Part III. Work Subcontracted to Others.

For each contract described in Part I, list all the work you have subcontracted to others.

	2	3	4	Awards Pending	1
Subcontractor					
Type of Work					
Subcontract Price					
Amount Uncompleted					
Subcontractor					
Type of Work					
Subcontract Price					
Amount Uncompleted					
Subcontractor					
Type of Work					
Subcontract Price					
Amount Uncompleted					
Subcontractor					
Type of Work					
Subcontract Price					
Amount Uncompleted					
Subcontractor					
Type of Work					
Subcontract Price					
Amount Uncompleted					
Total Uncompleted					

Notary

I, being duly sworn, do hereby declare this affidavit is a true and correct statement relating to ALL uncompleted contracts of the undersigned for Federal, State, County, City and private work, including ALL subcontract work, ALL pending low bids not yet awarded or rejected and ALL estimated completion dates.

Officer or Director

Title

Signature

Date

Company

Address

City

State

Zip Code

Subscribed and sworn to before me

this _____ day of _____, _____

(Signature of Notary Public)

My commission expires _____

(Notary Seal)

Add pages for additional contracts



Bureau of Construction
2300 South Dirksen Parkway/Room 322
Springfield, IL 62764

Instructions: Complete this form by either typing or using black ink. "Authorization to Bid" will not be issued unless both sides of this form are completed in detail. Use additional forms as needed to list all work.

Part I. Work Under Contract

List below all work you have under contract as either a prime contractor or a subcontractor. It is required to include all pending low bids not yet awarded or rejected. In a joint venture, list only that portion of the work which is the responsibility of your company. The uncompleted dollar value is to be based upon the most recent engineer's or owners estimate, and must include work subcontracted to others. If no work is contracted, show NONE.

	1	2	3	4	Awards Pending	Accumulated Totals
Contract Number						
Contract With						
Estimated Completion Date						
Total Contract Price						
Uncompleted Dollar Value if Firm is the Prime Contractor						
Uncompleted Dollar Value if Firm is the Subcontractor						
Total Value of All Work						

Part II. Awards Pending and Uncompleted Work to be done with your own forces.

List below the uncompleted dollar value of work for each contract and awards pending to be completed with your own forces. All work subcontracted to others will be listed on the reverse of this form. In a joint venture, list only that portion of the work to be done by your company. If no work is contracted, show NONE.

Earthwork						
Portland Cement Concrete Paving						
HMA Plant Mix						
HMA Paving						
Clean & Seal Cracks/Joints						
Aggregate Bases, Surfaces						
Highway, R.R., Waterway Struc.						
Drainage						
Electrical						
Cover and Seal Coats						
Concrete Construction						
Landscaping						
Fencing						
Guardrail						
Painting						
Signing						
Cold Milling, Planning, Rotomilling						
Demolition						
Pavement Markings (Paint)						
Other Construction (List)						
Totals						

Disclosure of this information is REQUIRED to accomplish the statutory purpose as outlined in the "Illinois Procurement Code." Failure to comply will result in non-issuance of an "Authorization To Bid." This form has been approved by the State Forms Management Center.

Part III. Work Subcontracted to Others.

For each contract described in Part I, list all the work you have subcontracted to others.

	1	2	3	4	Awards Pending
Subcontractor					
Type of Work					
Subcontract Price					
Amount Uncompleted					
Subcontractor					
Type of Work					
Subcontract Price					
Amount Uncompleted					
Subcontractor					
Type of Work					
Subcontract Price					
Amount Uncompleted					
Subcontractor					
Type of Work					
Subcontract Price					
Amount Uncompleted					
Subcontractor					
Type of Work					
Subcontract Price					
Amount Uncompleted					
Total Uncompleted					

Notary

I, being duly sworn, do hereby declare this affidavit is a true and correct statement relating to ALL uncompleted contracts of the undersigned for Federal, State, County, City and private work, including ALL subcontract work, ALL pending low bids not yet awarded or rejected and ALL estimated completion dates.

Officer or Director

Title

Signature

Date

Company

Address

City

State

Zip Code

Subscribed and sworn to before me

this _____ day of _____, _____

(Signature of Notary Public)

My commission expires _____

(Notary Seal)

Add pages for additional contracts



Bureau of Construction
2300 South Dirksen Parkway/Room 322
Springfield, IL 62764

Instructions: Complete this form by either typing or using black ink. "Authorization to Bid" will not be issued unless both sides of this form are completed in detail. Use additional forms as needed to list all work.

Part I. Work Under Contract

List below all work you have under contract as either a prime contractor or a subcontractor. It is required to include all pending low bids not yet awarded or rejected. In a joint venture, list only that portion of the work which is the responsibility of your company. The uncompleted dollar value is to be based upon the most recent engineer's or owners estimate, and must include work subcontracted to others. If no work is contracted, show NONE.

	1	2	3	4	Awards Pending	Accumulated Totals
Contract Number						
Contract With						
Estimated Completion Date						
Total Contract Price						
Uncompleted Dollar Value if Firm is the Prime Contractor						
Uncompleted Dollar Value if Firm is the Subcontractor						
Total Value of All Work						

Part II. Awards Pending and Uncompleted Work to be done with your own forces.

List below the uncompleted dollar value of work for each contract and awards pending to be completed with your own forces. All work subcontracted to others will be listed on the reverse of this form. In a joint venture, list only that portion of the work to be done by your company. If no work is contracted, show NONE.

Earthwork						
Portland Cement Concrete Paving						
HMA Plant Mix						
HMA Paving						
Clean & Seal Cracks/Joints						
Aggregate Bases, Surfaces						
Highway, R.R., Waterway Struc.						
Drainage						
Electrical						
Cover and Seal Coats						
Concrete Construction						
Landscaping						
Fencing						
Guardrail						
Painting						
Signing						
Cold Milling, Planning, Rotomilling						
Demolition						
Pavement Markings (Paint)						
Other Construction (List)						
Totals						

Disclosure of this information is REQUIRED to accomplish the statutory purpose as outlined in the "Illinois Procurement Code." Failure to comply will result in non-issuance of an "Authorization To Bid." This form has been approved by the State Forms Management Center.

Part III. Work Subcontracted to Others.

For each contract described in Part I, list all the work you have subcontracted to others.

	1	2	3	4	Awards Pending
Subcontractor					
Type of Work					
Subcontract Price					
Amount Uncompleted					
Subcontractor					
Type of Work					
Subcontract Price					
Amount Uncompleted					
Subcontractor					
Type of Work					
Subcontract Price					
Amount Uncompleted					
Subcontractor					
Type of Work					
Subcontract Price					
Amount Uncompleted					
Subcontractor					
Type of Work					
Subcontract Price					
Amount Uncompleted					
Total Uncompleted					

Notary

I, being duly sworn, do hereby declare this affidavit is a true and correct statement relating to ALL uncompleted contracts of the undersigned for Federal, State, County, City and private work, including ALL subcontract work, ALL pending low bids not yet awarded or rejected and ALL estimated completion dates.

Officer or Director

Title

Signature

Date

Company

Address

City

State

Zip Code

Subscribed and sworn to before me

this _____ day of _____, _____

(Signature of Notary Public)

My commission expires _____

(Notary Seal)

Add pages for additional contracts



Bureau of Construction
2300 South Dirksen Parkway/Room 322
Springfield, IL 62764

Instructions: Complete this form by either typing or using black ink. "Authorization to Bid" will not be issued unless both sides of this form are completed in detail. Use additional forms as needed to list all work.

Part I. Work Under Contract

List below all work you have under contract as either a prime contractor or a subcontractor. It is required to include all pending low bids not yet awarded or rejected. In a joint venture, list only that portion of the work which is the responsibility of your company. The uncompleted dollar value is to be based upon the most recent engineer's or owners estimate, and must include work subcontracted to others. If no work is contracted, show NONE.

	1	2	3	4	Awards Pending	Accumulated Totals
Contract Number						
Contract With						
Estimated Completion Date						
Total Contract Price						
Uncompleted Dollar Value if Firm is the Prime Contractor						
Uncompleted Dollar Value if Firm is the Subcontractor						
Total Value of All Work						

Part II. Awards Pending and Uncompleted Work to be done with your own forces.

List below the uncompleted dollar value of work for each contract and awards pending to be completed with your own forces. All work subcontracted to others will be listed on the reverse of this form. In a joint venture, list only that portion of the work to be done by your company. If no work is contracted, show NONE.

Earthwork						
Portland Cement Concrete Paving						
HMA Plant Mix						
HMA Paving						
Clean & Seal Cracks/Joints						
Aggregate Bases, Surfaces						
Highway, R.R., Waterway Struc.						
Drainage						
Electrical						
Cover and Seal Coats						
Concrete Construction						
Landscaping						
Fencing						
Guardrail						
Painting						
Signing						
Cold Milling, Planning, Rotomilling						
Demolition						
Pavement Markings (Paint)						
Other Construction (List)						
Totals						

Disclosure of this information is REQUIRED to accomplish the statutory purpose as outlined in the "Illinois Procurement Code." Failure to comply will result in non-issuance of an "Authorization To Bid." This form has been approved by the State Forms Management Center.

Part III. Work Subcontracted to Others.

For each contract described in Part I, list all the work you have subcontracted to others.

	1	2	3	4	Awards Pending
Subcontractor					
Type of Work					
Subcontract Price					
Amount Uncompleted					
Subcontractor					
Type of Work					
Subcontract Price					
Amount Uncompleted					
Subcontractor					
Type of Work					
Subcontract Price					
Amount Uncompleted					
Subcontractor					
Type of Work					
Subcontract Price					
Amount Uncompleted					
Subcontractor					
Type of Work					
Subcontract Price					
Amount Uncompleted					
Total Uncompleted					

Notary

I, being duly sworn, do hereby declare this affidavit is a true and correct statement relating to ALL uncompleted contracts of the undersigned for Federal, State, County, City and private work, including ALL subcontract work, ALL pending low bids not yet awarded or rejected and ALL estimated completion dates.

Officer or Director

Title

Signature

Date

Company

Address

City

State

Zip Code

Subscribed and sworn to before me
this _____ day of _____, _____

(Signature of Notary Public)

My commission expires _____

(Notary Seal)



Substance Abuse Prevention Program Certification



Contract Number	District	Letting Date
	3	
Route	County	
East North Avenue	DeKalb	
Project Number	Job Number	
Section Number		

The Substance Abuse Prevention on Public Works Act, Public Act 95-0635, prohibits the use of drugs and alcohol, as defined in the Act, by employees of the Contractor and by employees of all approved Subcontractors while performing work on a public works project. The Contractor/Subcontractor herewith certifies that it has a superseding collective bargaining agreement or makes the public filing of its written substance abuse prevention program for the prevention of substance abuse among its employees who are not covered by a collective bargaining agreement dealing with the subject as mandated by the Act.

A. The undersigned representative of the Contractor/Subcontractor certifies that the contracting entity has signed collective bargaining agreements that are in effect for all of its employees, and that deal with the subject matter of Public Act 95-0635.

Contractor/Subcontractor

Name of Authorized Representative (type or print)

Title of Authorized Representative (type or print)

Signature of Authorized Representative

Date

B. The undersigned representative of the Contractor/Subcontractor certifies that the contracting entity has in place for all of its employees not covered by a collective bargaining agreement that deals with the subject of the Act, the attached substance abuse prevention program that meets or exceeds the requirements of Public Act 95-0635.

Contractor/Subcontractor

Name of Authorized Representative (type or print)

Title of Authorized Representative (type or print)

Signature of Authorized Representative

Date



Local Public Agency	County	Section Number
Town of Cortland	DeKalb	

The following Special Provision supplement the "Standard Specifications for Road and Bridge Construction", adopted

January 1, 2022, the latest edition of the "Manual on Uniform Traffic Control Devices for Streets and Highways", and the "Manual of Test Procedures of Materials" in effect on the date of invitation of bids, and the Supplemental Specification and Recurring Special Provisions indicated on the Check Sheet included here in which apply to and govern the construction of the above named section, and in case of conflict with any parts, or parts of said Specifications, the said Special Provisions shall take precedence and shall govern.

DESCRIPTION OF WORK

The work of this section shall consist of surface removal, placing of Hot Mix Asphalt Binder and Surface and other incidental work on East North Avenue.

GENERAL CONDITIONS

The work shall be completed by October 30, 2026. If the work is not completed by the deadline specified above, the Calendar Day charge per day as specified in Article 108.09 shall apply.

PROSECUTION OF WORK

The contractor shall notify the Engineer a minimum of two (2) working days (i.e. notice given on Thursday AM for work to begin the following Monday) prior to the commencement of any work which could be considered as a pay item in the contract. No payment will be made to the Contractor for any pay item work performed without the aforementioned notice being given unless otherwise approved by the Engineer. Work shall be performed between sunrise and sunset only.

TRAFFIC CONTROL

Traffic Control shall be in accordance with the applicable sections of the Standard Specifications for Road and Bridge Construction, the applicable guidelines contained in the manual on Uniform Traffic Control Devices for Streets and Highways, these Special Provisions, and any special details and Highway Standards contained herein and in the plans.

Standards 701301, 701311, 701901.

The entire section shall remain open to a minimum of one lane traffic during construction. After hours of operation each day, the contractor shall open both lanes to overnight traffic.

The presence of temporary traffic control drawings or standards in the project plans, whether a pay item or not, does not relieve the contractor of his obligation to the public, in accordance with Article 107.14 of the Standard Specifications for Road and Bridge Construction. The contractor shall provide, to the satisfaction of the Engineer, all protection deemed necessary beyond that shown in the plans or Special Provision.

Flaggers shall comply with all requirements contained in the Department's "Flagger Handbook" with the following exception: The ANSI Class 2 vest will not be supplied by the Department or Town.

Traffic Control shall be done in accordance with the applicable traffic standards included in the proposal and adequate access and protection shall be provided for local residents. The cost of any and all traffic control required by these special provisions and the standards included in this proposal shall be considered incidental to the contract.

The Contractor shall post temporary "No Parking" signage with dates of work indicated a minimum of 48 hours prior to road work or closure.

Town of Cortland

DeKalb

HOT MIX ASPHALT SURFACE REMOVAL 2"

Millings generated via self-propelled milling machine during HMA surface removal shall be delivered by the contractor to the Town property on East North Avenue. This shall be considered incidental to the HMA surface removal.

After HMA surface removal, the existing aggregate base shall be finish graded and rolled as needed. This shall be considered incidental to the HMA surface removal.

Local Quality Assurance / Quality Management QC/QA for HMA will be performed per LR1030-2.

Quantities are estimates prepared for the establishment of pay item prices and are the responsibility of the contractor to confirm prior to bidding. Quantities may be increased, decreased, or omitted to satisfactorily complete the project.

MOBILIZATION

Section 671 in the Standard Specification shall be deleted and no advance payment for Mobilization shall be granted. Mobilization shall be considered incidental to the contract.

Aggregate shoulders are not included in this contract and will be placed by the Town after paving is complete.

SPECIAL PROVISION FOR BIDDING REQUIREMENTS AND CONDITIONS FOR CONTRACT PROPOSALS (LRS6):

Prequalification of Bidders The provisions for prequalification of bidders as stated in the second paragraph shall apply to this proposal. Revise the second paragraph of this special provision to read:

"All bidders must file at the time of the letting a sworn affidavit, in duplicate, showing all uncompleted contracts awarded to them and all low bids pending award for federal, state, county, municipal, and private work, using blank forms made available for this affidavit. All copies shall be filed with the awarding authority."

A current Certificate of Eligibility must be presented to Town of Cortland prior to the town receiving bid documents.

PREVAILING WAGE

The Contractor(s) shall pay prevailing wage to employees on this project. The Contractor shall be responsible for obtaining monthly rate sheet from the Illinois Department of Labor. These sheets are also available at the DeKalb County Clerk's office or at:

<https://www2.illinois.gov/idol/Laws-Rules/CONMED/Pages/Rates.aspx>

INDEX
FOR
SUPPLEMENTAL SPECIFICATIONS
AND RECURRING SPECIAL PROVISIONS

Adopted January 1, 2026

This index contains a listing of SUPPLEMENTAL SPECIFICATIONS, frequently used RECURRING SPECIAL PROVISIONS, and LOCAL ROADS AND STREETS RECURRING SPECIAL PROVISIONS.

ERRATA Standard Specifications for Road and Bridge Construction
(Adopted 1-1-22) (Revised 1-1-26)

SUPPLEMENTAL SPECIFICATIONS

<u>Std. Spec. Sec.</u>	<u>Page No.</u>
109 Measurement and Payment	1
202 Earth and Rock Excavation	2
204 Borrow and Furnished Excavation	3
207 Porous Granular Embankment	4
211 Topsoil and Compost	5
214 Grading and Shaping Ditches	6
406 Hot-Mix Asphalt Binder and Surface Course	7
407 Hot-Mix Asphalt Pavement (Full-Depth)	9
420 Portland Cement Concrete Pavement	10
502 Excavation for Structures	11
504 Precast Concrete Structures	12
509 Metal Railings	13
522 Retaining Walls	14
540 Box Culverts	15
542 Pipe Culverts	35
550 Storm Sewers	44
586 Granular Backfill for Structures	51
601 Pipe Drains, Pipe Underdrains, and French Drains	52
630 Steel Plate Beam Guardrail	53
632 Guardrail and Cable Road Guard Removal	54
644 High Tension Cable Median Barrier	55
665 Woven Wire Fence	56
701 Work Zone Traffic Control and Protection	57
781 Raised Reflective Pavement Markers	59
782 Reflectors	60
801 Electrical Requirements	62
821 Roadway Luminaires	65
1003 Fine Aggregates	66
1004 Coarse Aggregates	67
1010 Finely Divided Minerals	69
1020 Portland Cement Concrete	70
1030 Hot-Mix Asphalt	73
1040 Drain Pipe, Tile, and Wall Drain	74
1042 Precast Concrete Products	75
1061 Waterproofing Membrane System	76
1067 Luminaire	77
1097 Reflectors	84
1102 Hot-Mix Asphalt Equipment	85

RECURRING SPECIAL PROVISIONS

The following RECURRING SPECIAL PROVISIONS indicated by an "X" are applicable to this contract and are included by reference:

<u>CHECK SHEET #</u>		<u>PAGE NO.</u>
1	Additional State Requirements for Federal-Aid Construction Contracts	87
2	Subletting of Contracts (Federal-Aid Contracts)	90
3	EEO	91
4	Specific EEO Responsibilities Nonfederal-Aid Contracts	101
5	Required Provisions - State Contracts	106
6	Asbestos Bearing Pad Removal	112
7	Asbestos Waterproofing Membrane and Asbestos Hot-Mix Asphalt Surface Removal	113
8	Temporary Stream Crossings and In-Stream Work Pads	114
9	Construction Layout Stakes	115
10	Use of Geotextile Fabric for Railroad Crossing	118
11	Subsealing of Concrete Pavements	120
12	Hot-Mix Asphalt Surface Correction	124
13	Pavement and Shoulder Resurfacing	126
14	Patching with Hot-Mix Asphalt Overlay Removal	127
15	Polymer Concrete	129
16	Reserved	131
17	Bicycle Racks	132
18	Temporary Portable Bridge Traffic Signals	134
19	Nighttime Inspection of Roadway Lighting	136
20	English Substitution of Metric Bolts	137
21	Calcium Chloride Accelerator for Portland Cement Concrete	138
22	Quality Control of Concrete Mixtures at the Plant	139
23	Quality Control/Quality Assurance of Concrete Mixtures	147
24	Reserved	163
25	Reserved	164
26	Temporary Raised Pavement Markers	165
27	Restoring Bridge Approach Pavements Using High-Density Foam	166
28	Portland Cement Concrete Inlay or Overlay	169
29	Portland Cement Concrete Partial Depth Hot-Mix Asphalt Patching	173
30	Longitudinal Joint and Crack Patching	176
31	Concrete Mix Design – Department Provided	178
32	Station Numbers in Pavements or Overlays	179



Local Public Agency	County	Section Number
Town of Cortland	DeKalb	

Check this box for lettings prior to 01/01/2026

The Following Recurring Special Provisions Indicated By An "X" Are Applicable To This Contract And Are Included By Reference:

Recurring Special Provisions

<u>Check Sheet #</u>		<u>Page No.</u>
1	<input type="checkbox"/> Additional State Requirements for Federal-Aid Construction Contracts	87
2	<input type="checkbox"/> Subletting of Contracts (Federal-Aid Contracts)	90
3	<input type="checkbox"/> EEO	91
4	<input type="checkbox"/> Specific EEO Responsibilities Non Federal-Aid Contracts	101
5	<input type="checkbox"/> Required Provisions - State Contracts	106
6	<input type="checkbox"/> Asbestos Bearing Pad Removal	112
7	<input type="checkbox"/> Asbestos Waterproofing Membrane and Asbestos HMA Surface Removal	113
8	<input type="checkbox"/> Temporary Stream Crossings and In-Stream Work Pads	114
9	<input type="checkbox"/> Construction Layout Stakes	115
10	<input type="checkbox"/> Use of Geotextile Fabric for Railroad Crossing	118
11	<input type="checkbox"/> Subsealing of Concrete Pavements	120
12	<input type="checkbox"/> Hot-Mix Asphalt Surface Correction	124
13	<input type="checkbox"/> Pavement and Shoulder Resurfacing	126
14	<input type="checkbox"/> Patching with Hot-Mix Asphalt Overlay Removal	127
15	<input type="checkbox"/> Polymer Concrete	129
16	<input type="checkbox"/> Reserved	131
17	<input type="checkbox"/> Bicycle Racks	132
18	<input type="checkbox"/> Temporary Portable Bridge Traffic Signals	134
19	<input type="checkbox"/> Nighttime Inspection of Roadway Lighting	136
20	<input type="checkbox"/> English Substitution of Metric Bolts	137
21	<input type="checkbox"/> Calcium Chloride Accelerator for Portland Cement Concrete	138
22	<input type="checkbox"/> Quality Control of Concrete Mixtures at the Plant	139
23	<input type="checkbox"/> Quality Control/Quality Assurance of Concrete Mixtures	147
24	<input type="checkbox"/> Reserved	163
25	<input type="checkbox"/> Reserved	164
26	<input type="checkbox"/> Temporary Raised Pavement Markers	165
27	<input type="checkbox"/> Restoring Bridge Approach Pavements Using High-Density Foam	166
28	<input type="checkbox"/> Portland Cement Concrete Inlay or Overlay	169
29	<input type="checkbox"/> Portland Cement Concrete Partial Depth Hot-Mix Asphalt Patching	173
30	<input type="checkbox"/> Longitudinal Joint and Crack Patching	176
31	<input type="checkbox"/> Concrete Mix Design - Department Provided	178
32	<input type="checkbox"/> Station Numbers in Pavements or Overlays	179

Local Public Agency

County

Section Number

Town of Cortland

DeKalb

The Following Local Roads And Streets Recurring Special Provisions Indicated By An "X" Are Applicable To This Contract And Are Included By Reference:

Local Roads And Streets Recurring Special Provisions

<u>Check Sheet #</u>		<u>Page No.</u>
LRS 1	Reserved	181
LRS 2	<input type="checkbox"/> Furnished Excavation	182
LRS 3	<input checked="" type="checkbox"/> Work Zone Traffic Control Surveillance	183
LRS 4	<input checked="" type="checkbox"/> Flaggers in Work Zones	184
LRS 5	<input checked="" type="checkbox"/> Contract Claims	185
LRS 6	<input checked="" type="checkbox"/> Bidding Requirements and Conditions for Contract Proposals	186
LRS 7	<input type="checkbox"/> Bidding Requirements and Conditions for Material Proposals	192
LRS 8	Reserved	198
LRS 9	<input type="checkbox"/> Bituminous Surface Treatments	199
LRS 10	Reserved	203
LRS 11	<input checked="" type="checkbox"/> Employment Practices	204
LRS 12	<input checked="" type="checkbox"/> Wages of Employees on Public Works	206
LRS 13	<input checked="" type="checkbox"/> Selection of Labor	208
LRS 14	<input type="checkbox"/> Paving Brick and Concrete Paver Pavements and Sidewalks	209
LRS 15	<input checked="" type="checkbox"/> Partial Payments	212
LRS 16	<input checked="" type="checkbox"/> Protests on Local Lettings	213
LRS 17	<input checked="" type="checkbox"/> Substance Abuse Prevention Program	214
LRS 18	<input type="checkbox"/> Multigrade Cold Mix Asphalt	215
LRS 19	<input type="checkbox"/> Reflective Crack Control Treatment	216

State of Illinois
Department of Transportation
Bureau of Local Roads and Streets

SPECIAL PROVISION
FOR
INSURANCE

Effective: February 1, 2007
Revised: August 1, 2007

All references to Sections or Articles in this specification shall be construed to mean specific Section or Article of the Standard Specifications for Road and Bridge Construction, adopted by the Department of Transportation.

The Contractor shall name the following entities as additional insured under the Contractor's general liability insurance policy in accordance with Article 107.27:

Town of Cortland

The entities listed above and their officers, employees, and agents shall be indemnified and held harmless in accordance with Article 107.26.

State of Illinois
DEPARTMENT OF TRANSPORTATION
Bureau of Local Roads & Streets
SPECIAL PROVISION
FOR
LOCAL QUALITY ASSURANCE/ QUALITY MANAGEMENT QC/QA
Effective: January 1, 2022

Replace the first five paragraphs of Article 1030.06 of the Standard Specifications with the following:

“1030.06 Quality Management Program. The Quality Management Program (QMP) will be Quality Control / Quality Assurance (QC/QA) according to the following.”

Delete Article 1030.06(d)(1) of the Standard Specifications.

Revise Article 1030.09(g)(3) of the Standard Specifications to read:

“(3) If core testing is the density verification method, the Contractor shall provide personnel and equipment to collect density verification cores for the Engineer. Core locations will be determined by the Engineer following the document “Hot-Mix Asphalt QC/QA Procedure for Determining Random Density Locations” at density verification intervals defined in Article 1030.09(b). After the Engineer identifies a density verification location and prior to opening to traffic, the Contractor shall cut a 4 in. (100 mm) diameter core. With the approval of the Engineer, the cores may be cut at a later time.”

Revise Article 1030.09(h)(2) of the Standard Specifications to read:

“(2) After final rolling and prior to paving subsequent lifts, the Engineer will identify the random density verification test locations. Cores or nuclear density gauge testing will be used for density verification. The method used for density verification will be as selected below.

Density Verification Method	
<input type="checkbox"/>	Cores
<input checked="" type="checkbox"/>	Nuclear Density Gauge (Correlated when paving \geq 3,000 tons per mixture)

Density verification test locations will be determined according to the document “Hot-Mix Asphalt QC/QA Procedure for Determining Random Density Locations”. The density testing interval for paving wider than or equal to 3 ft (1 m) will be 0.5 miles (800 m) for lift thicknesses of 3 in. (75 mm) or less and 0.2 miles (320 m) for lift thicknesses greater than 3 in. (75 mm). The density testing interval for paving less than 3 ft (1 m) wide will be 1 mile (1,600 m). If a day’s paving will be less than the prescribed density testing interval, the length of the day’s paving will be the interval for that day. The density testing interval for mixtures used for patching will be 50 patches with a minimum of one test per mixture per project.

If core testing is the density verification method, the Engineer will witness the Contractor coring, and secure and take possession of all density samples at the

density verification locations. The Engineer will test the cores collected by the Contractor for density according to Illinois Modified AASHTO T 166 or AASHTO T 275.

If nuclear density gauge testing is the density verification method, the Engineer will conduct nuclear density gauge tests. The Engineer will follow the density testing procedure detailed in the document "Illinois Modified ASTM D 2950, Standard Test Method for Density of Bituminous Concrete In-Place by Nuclear Method".

A density verification test will be the result of a single core or the average of the nuclear density tests at one location. The results of each density test must be within acceptable limits. The Engineer will promptly notify the Contractor of observed deficiencies."

Revise the seventh paragraph and all subsequent paragraphs in Section D. of the document "Hot-Mix Asphalt QC/QA Initial Daily Plant and Random Samples" to read:

"Mixtures shall be sampled from the truck at the plant by the Contractor following the same procedure used to collect QC mixture samples (Section A). This process will be witnessed by the Engineer who will take custody of the verification sample. Each sample bag with a verification mixture sample will be secured by the Engineer using a locking ID tag. Sample boxes containing the verification mixture sample will be sealed/taped by the Engineer using a security ID label."

BDE SPECIAL PROVISIONS
For the January 16 and February 27, 2026 Lettings

The following special provisions indicated by a "check mark" are applicable to this contract and will be included by the Project Coordination and Implementation Section of the Bureau of Design & Environment (BDE).

File Name	#		Special Provision Title	Effective	Revised	
	80099	1	<input type="checkbox"/>	Accessible Pedestrian Signals (APS)	April 1, 2003	Jan. 1, 2022
	80274	2	<input type="checkbox"/>	Aggregate Subgrade Improvement	April 1, 2012	April 1, 2022
	80192	3	<input type="checkbox"/>	Automated Flagger Assistance Devices	Jan. 1, 2008	April 1, 2023
	80173	4	<input type="checkbox"/>	Bituminous Materials Cost Adjustments	Nov. 2, 2006	Aug. 1, 2017
	80426	5	<input type="checkbox"/>	Bituminous Surface Treatment with Fog Seal	Jan. 1, 2020	Jan. 1, 2022
	80475	6	<input type="checkbox"/>	Bridge Deck Concrete Overlays	Jan. 1, 2026	
*	80241	7	<input type="checkbox"/>	Bridge Demolition Debris	July 1, 2009	
*	50531	8	<input type="checkbox"/>	Building Removal	Sept. 1, 1990	Aug. 1, 2022
*	50261	9	<input type="checkbox"/>	Building Removal with Asbestos Abatement	Sept. 1, 1990	Aug. 1, 2022
	80460	10	<input type="checkbox"/>	Cement, Finely Divided Minerals, Admixtures, Concrete, and Mortar	Jan. 1, 2025	Jan. 1, 2026
	80384	11	<input checked="" type="checkbox"/>	Compensable Delay Costs	June 2, 2017	April 1, 2019
*	80198	12	<input type="checkbox"/>	Completion Date (via calendar days)	April 1, 2008	
*	80199	13	<input type="checkbox"/>	Completion Date (via calendar days) Plus Working Days	April 1, 2008	
	80461	14	<input type="checkbox"/>	Concrete Barrier	Jan. 1, 2025	
	80453	15	<input type="checkbox"/>	Concrete Sealer	Nov. 1, 2023	
	80261	16	<input type="checkbox"/>	Construction Air Quality – Diesel Retrofit	June 1, 2010	Jan. 1, 2025
	80476	17	<input type="checkbox"/>	Deck Slab Repair	Jan. 1, 2026	
*	80029	18	<input type="checkbox"/>	Disadvantaged Business Enterprise Participation	Sept. 1, 2000	Jan. 2, 2025
	80467	19	<input type="checkbox"/>	Erosion Control Blanket	Aug. 1, 2025	
	80229	20	<input type="checkbox"/>	Fuel Cost Adjustment	April 1, 2009	Aug. 1, 2017
	80452	21	<input type="checkbox"/>	Full Lane Sealant Waterproofing System	Nov. 1, 2023	
	80433	22	<input type="checkbox"/>	Green Preformed Thermoplastic Pavement Markings	Jan. 1, 2021	Jan. 1, 2022
	80471	23	<input type="checkbox"/>	Guardrail	Nov. 1, 2025	
	80472	24	<input type="checkbox"/>	High Friction Surface Treatment	Nov. 1, 2025	
	80456	25	<input checked="" type="checkbox"/>	Hot-Mix Asphalt	Jan. 1, 2024	Jan. 1, 2026
	80446	26	<input checked="" type="checkbox"/>	Hot-Mix Asphalt - Longitudinal Joint Sealant	Nov. 1, 2022	Aug. 1, 2023
	80438	27	<input type="checkbox"/>	Illinois Works Apprenticeship Initiative – State Funded Contracts	June 2, 2021	April 2, 2024
	80477	28	<input type="checkbox"/>	Longitudinal Tining	Jan. 1, 2026	
	80450	29	<input type="checkbox"/>	Mechanically Stabilized Earth Retaining Walls	Aug. 1, 2023	Aug. 1, 2025
	80478	30	<input type="checkbox"/>	Modified Longitudinal Construction Joint	Jan. 1, 2026	
	80464	31	<input type="checkbox"/>	Pavement Marking	April. 1, 2025	Nov. 1, 2025
	80468	32	<input type="checkbox"/>	Pavement Patching	Aug. 1, 2025	
	80441	33	<input type="checkbox"/>	Performance Graded Asphalt Binder	Jan. 1, 2023	
	80459	34	<input type="checkbox"/>	Preformed Plastic Pavement Marking	June 2, 2024	
*	34261	35	<input type="checkbox"/>	Railroad Protective Liability Insurance	Dec. 1, 1986	Jan. 1, 2022
	80473	36	<input type="checkbox"/>	Raised Reflective Pavement Markers	Nov. 1, 2025	
	80455	37	<input type="checkbox"/>	Removal and Disposal of Regulated Substances	Jan. 1, 2024	April 1, 2024
	80474	38	<input type="checkbox"/>	Residential Driveway Temporary Signal	Nov. 1, 2025	
	80445	39	<input type="checkbox"/>	Seeding	Nov. 1, 2022	
	80457	40	<input type="checkbox"/>	Short Term and Temporary Pavement Markings	April 1, 2024	April 2, 2024
	80462	41	<input type="checkbox"/>	Sign Panels and Appurtenances	Jan. 1, 2025	Jan. 1, 2026
	80479	42	<input type="checkbox"/>	Sinusoidal Rumble Strips	Jan. 1, 2026	
	80469	43	<input type="checkbox"/>	Slope Wall	Aug. 1, 2025	
	80448	44	<input type="checkbox"/>	Source of Supply and Quality Requirements	Jan. 2, 2023	Jan. 1, 2026
	80340	45	<input type="checkbox"/>	Speed Display Trailer	April 2, 2014	Jan. 1, 2022
	80127	46	<input type="checkbox"/>	Steel Cost Adjustment	April 2, 2004	Nov. 1, 2025
	80480	47	<input type="checkbox"/>	Structural Repair of Concrete	Jan. 1, 2026	
	80397	48	<input type="checkbox"/>	Subcontractor and DBE Payment Reporting	April 2, 2018	
	80391	49	<input type="checkbox"/>	Subcontractor Mobilization Payments	Nov. 2, 2017	April 1, 2019
	80463	50	<input type="checkbox"/>	Submission of Bidders List Information	Jan. 2, 2025	Mar. 2, 2025
	80437	51	<input type="checkbox"/>	Submission of Payroll Records	April 1, 2021	Nov. 2, 2023

	80435	52	<input type="checkbox"/>	Surface Testing of Pavements – IRI	Jan. 1, 2021	Jan. 1, 2023
	80465	53	<input type="checkbox"/>	Surveying Services	April 1, 2025	
	80481	54	<input checked="" type="checkbox"/>	Temporary Concrete Barrier	Jan. 1, 2026	
	80466	55	<input type="checkbox"/>	Temporary Rumble Strips	April 1, 2025	
	80470	56	<input type="checkbox"/>	Traffic Signal Backplate	Aug. 1, 2025	
*	20338	57	<input type="checkbox"/>	Training Special Provisions	Oct. 15, 1975	Sept. 2, 2021
	80429	58	<input type="checkbox"/>	Ultra-Thin Bonded Wearing Course	April 1, 2020	Jan. 1, 2022
	80439	59	<input type="checkbox"/>	Vehicle and Equipment Warning Lights	Nov. 1, 2021	Nov. 1, 2022
	80458	60	<input type="checkbox"/>	Waterproofing Membrane System	Aug. 1, 2024	
	80302	61	<input type="checkbox"/>	Weekly DBE Trucking Reports	June 2, 2012	Jan. 2, 2025
	80454	62	<input type="checkbox"/>	Wood Sign Support	Nov. 1, 2023	
	80427	63	<input checked="" type="checkbox"/>	Work Zone Traffic Control Devices	Mar. 2, 2020	Jan. 1, 2026
*	80071	64	<input type="checkbox"/>	Working Days	Jan. 1, 2002	

Highlighted items indicate a new or revised special provision for the letting.

An * indicates the special provision requires additional information from the designer, which needs to be submitted separately. The Project Coordination and Implementation Section will then include the information in the applicable special provision.

The following special provisions are in the 2026 Supplemental Specifications and Recurring Special Provisions.

<u>File Name</u>	<u>Special Provision Title</u>	<u>New Location(s)</u>	<u>Effective</u>	<u>Revised</u>
80447	Grading and Shaping Ditches	Articles 214.03 & 214.04	Jan. 1, 2023	

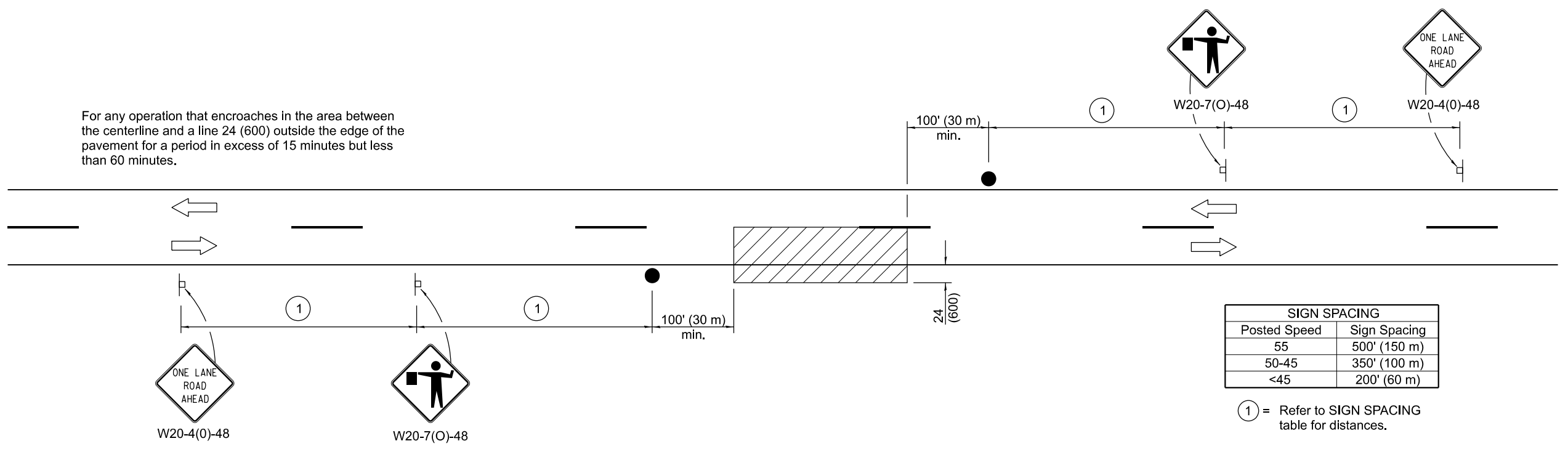
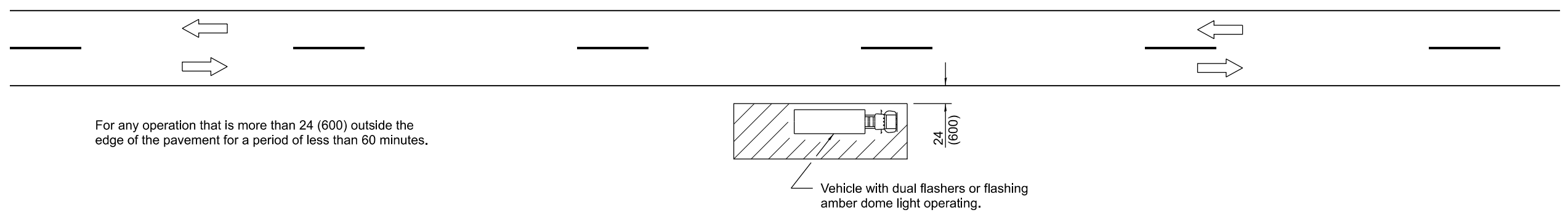
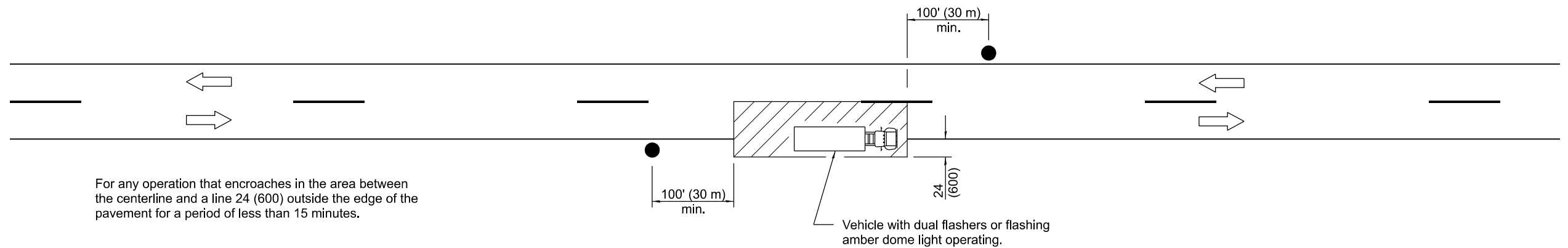

SIGN SPACING	
Posted Speed	Sign Spacing
55	500' (150 m)
50-45	350' (100 m)
<45	200' (60 m)

① = Refer to SIGN SPACING table for distances.

TYPICAL APPLICATIONS

- Marking patches
- Field survey
- String line
- Utility operations
- Cleaning up debris on pavement

SYMBOLS

- Work area
- Sign on portable or permanent support
- Flagger with traffic control sign

All dimensions are in inches (millimeters) unless otherwise shown.

Illinois Department of Transportation

APPROVED January 1, 2011
Amelia A. Davis
 ENGINEER OF SAFETY ENGINEERING

APPROVED January 1, 2011
Scott Schickel
 ENGINEER OF DESIGN AND ENVIRONMENT

ISSUED 1-1-97

DATE	REVISIONS
1-1-11	Revised flagger sign.
1-1-09	Switched units to English (metric).

**LANE CLOSURE, 2L, 2W,
SHORT TIME OPERATIONS**

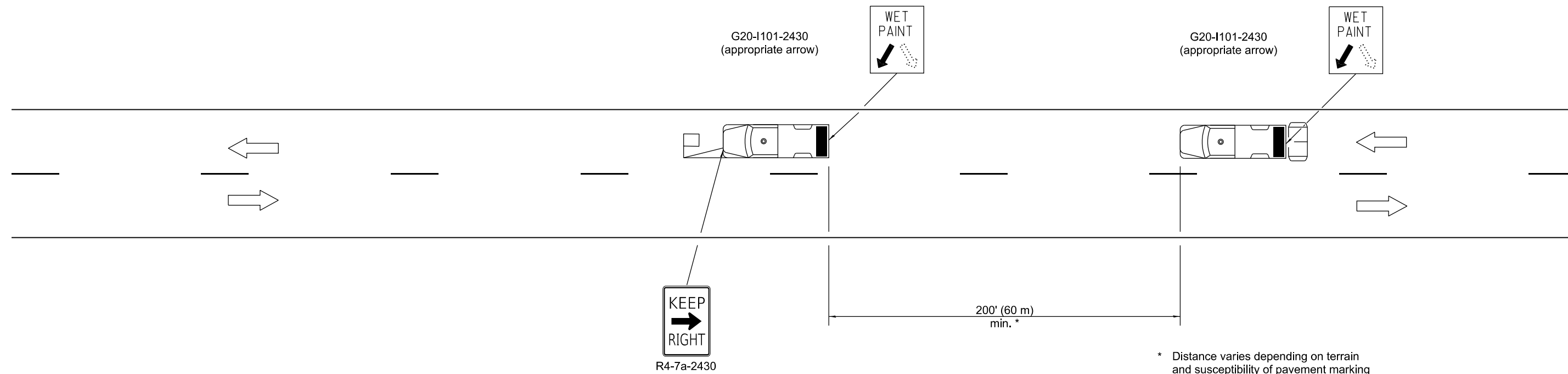

STANDARD 701301-04



TYPICAL APPLICATIONS

- Landscaping work
- Utility work
- Pavement marking
- Weed spraying
- Roadometer measurements
- Debris cleanup
- Crack pouring

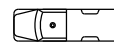
SYMBOLS

-  Arrow board (Hazard Mode only)
-  Truck with headlights, emergency flashers and flashing amber light. (visible from all directions)
-  18 x 18 (450x450) min. orange flag (use when guide wheel is used)
-  Truck mounted attenuator

GENERAL NOTES

This Standard is used where any vehicle, equipment, workers or their activities will require a continuous moving operation where the average speed is greater than 3 mph (5 km/h).

For shoulder operations not encroaching on the pavement, use DETAIL A, Standard 701426.

All dimensions are in inches (millimeters) unless otherwise shown.

Illinois Department of Transportation

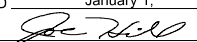
APPROVED January 1, 2009

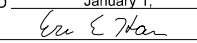
 ENGINEER OF OPERATIONS

APPROVED January 1, 2009

 ENGINEER OF DESIGN AND ENVIRONMENT

ISSUED 1-1-97

DATE	REVISIONS
1-1-09	Switched units to English (metric). Omitted Pass With Care sign.
1-1-00	Eliminated speed restrictions in Standard title.

**LANE CLOSURE 2L, 2W
MOVING OPERATIONS-
DAY ONLY**

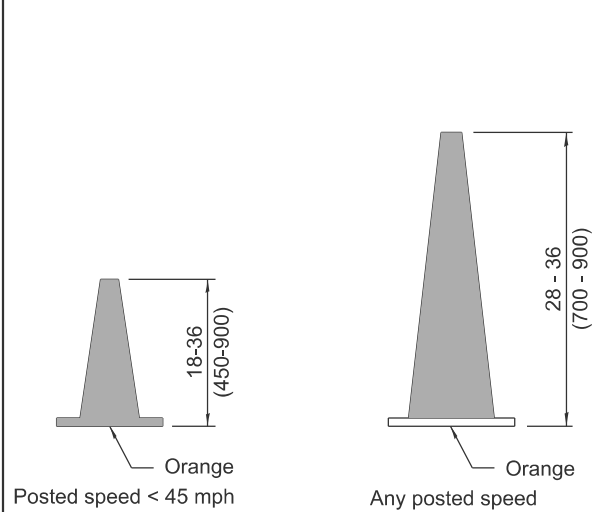
STANDARD 701311-03



DAYTIME USE

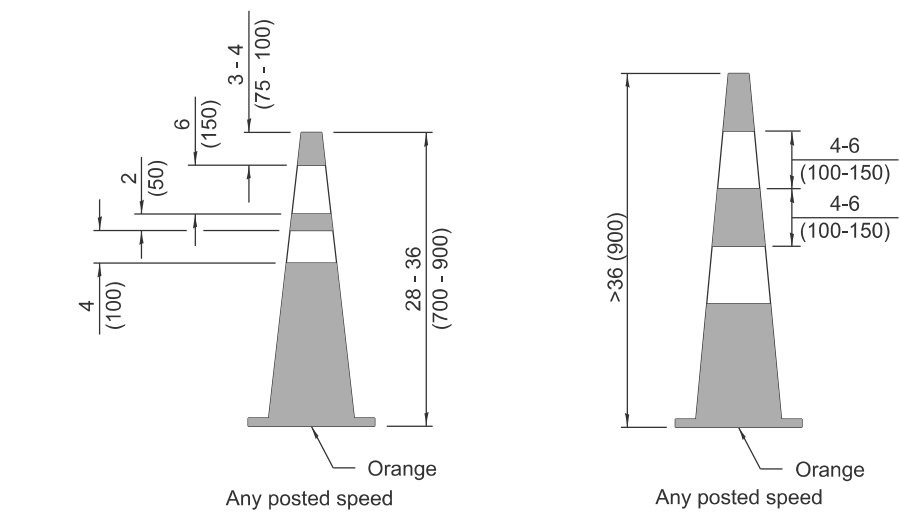

DAY OR NIGHTTIME USE

CONES

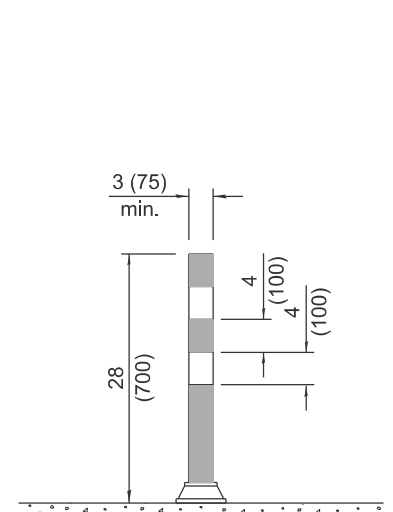

TUBULAR MARKER

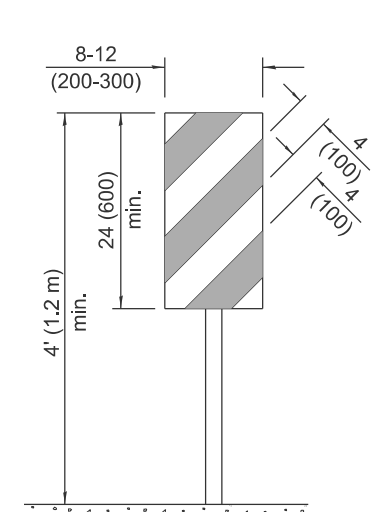

**VERTICAL PANEL
POST MOUNTED**

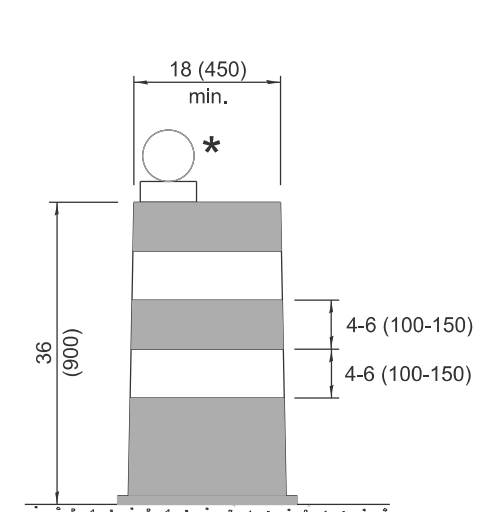

DRUM

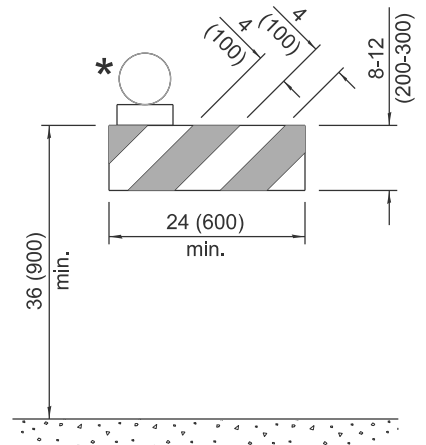

TYPE I BARRICADE

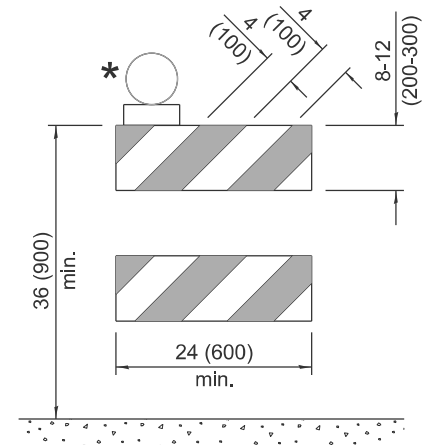

TYPE II BARRICADE

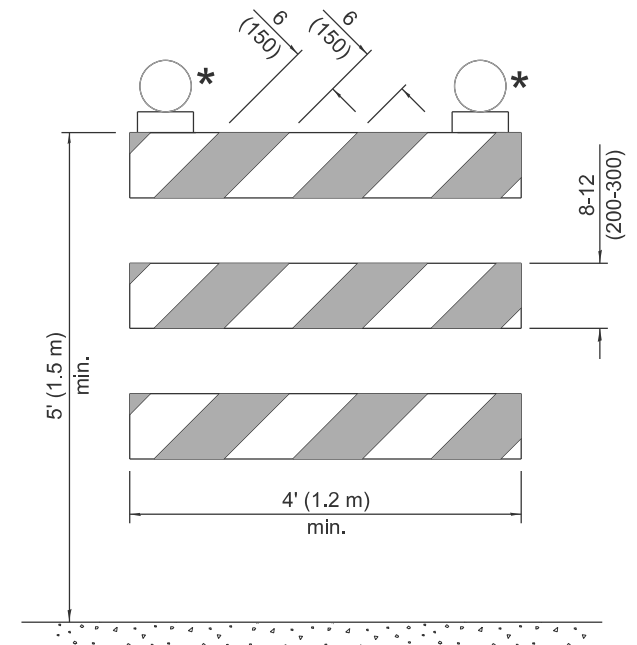

TYPE III BARRICADE

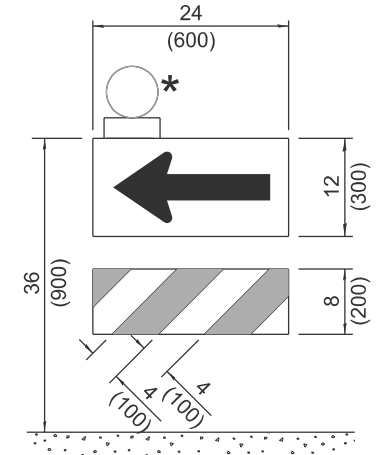

**DIRECTION INDICATOR
BARRICADE**

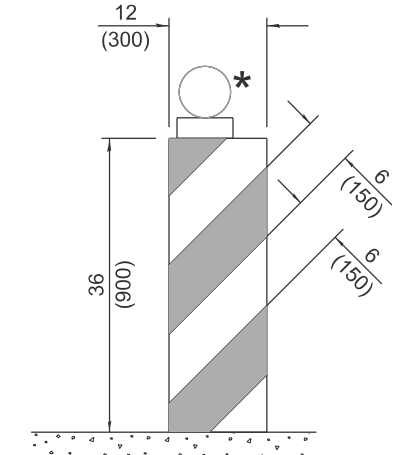

VERTICAL BARRICADE

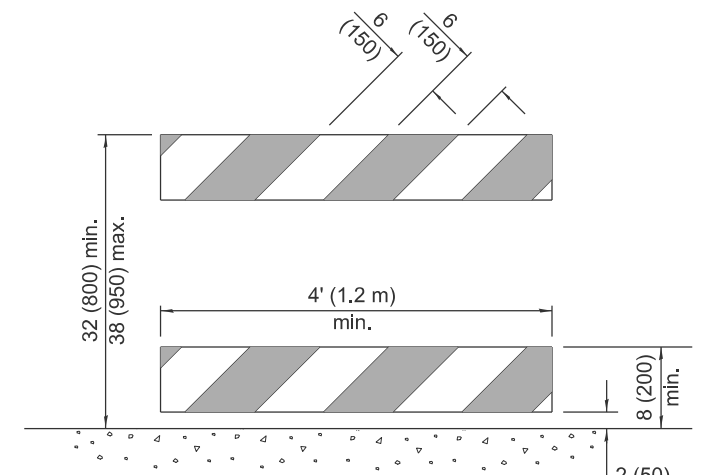

**DETECTABLE PEDESTRIAN
CHANNELIZING BARRICADE**

* Warning lights (if required)

GENERAL NOTES

All heights shown shall be measured above the pavement surface.

All dimensions are in inches (millimeters) unless otherwise shown.

DATE	REVISIONS
1-1-26	Updated Detectable Pedestrian Channelizing Barricade (sht. 1) & Temporary Rumble Strips details (sht. 3)
1-1-25	Updated Temporary Rumble Strip Detail (sht. 3).

TRAFFIC CONTROL DEVICES

(Sheet 1 of 3)

STANDARD 701901-11

Illinois Department of Transportation

APPROVED January 1, 2026
ENGINEER OF SAFETY PROG. AND ENGINEERING

APPROVED January 1, 2026
ENGINEER OF DESIGN AND ENVIRONMENT

ISSUED 1-1-13

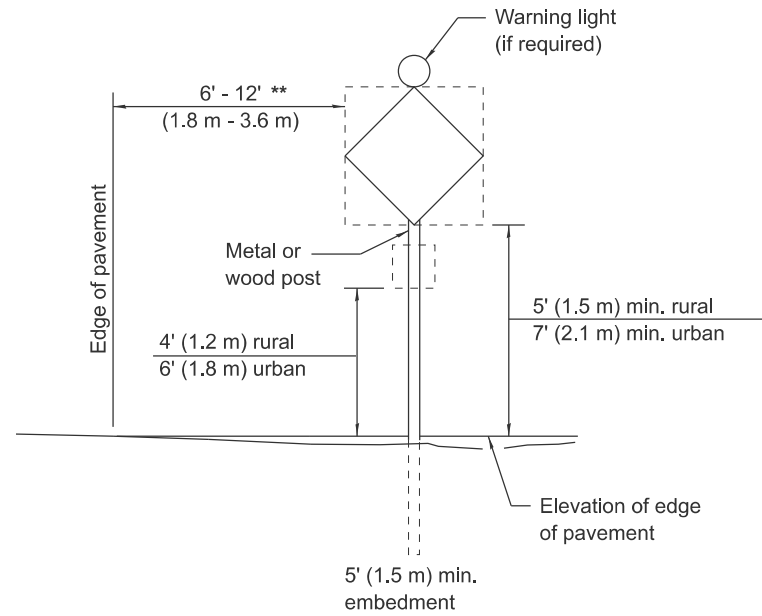

POST MOUNTED SIGNS

** When curb or paved shoulder are present this dimension shall be 24 (600) to the face of curb or 6' (1.8 m) to the outside edge of the paved shoulder.

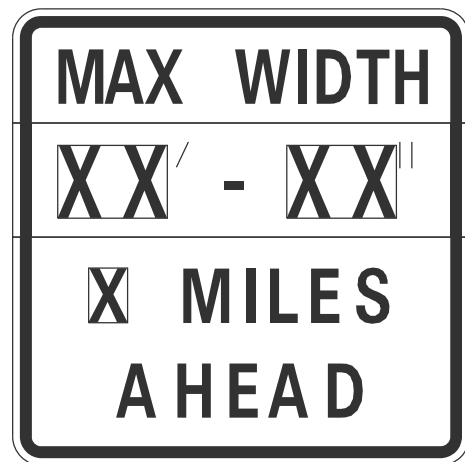

W12-1103-4848

WIDTH RESTRICTION SIGN

XX'-XX" width and X miles are variable.

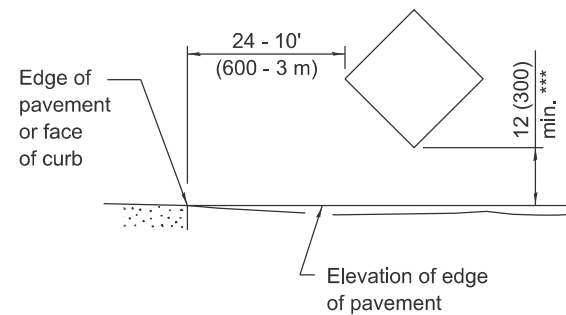

SIGNS ON TEMPORARY SUPPORTS

*** When work operations exceed four days, this dimension shall be 5' (1.5 m) min. If located behind other devices, the height shall be sufficient to be seen completely above the devices.

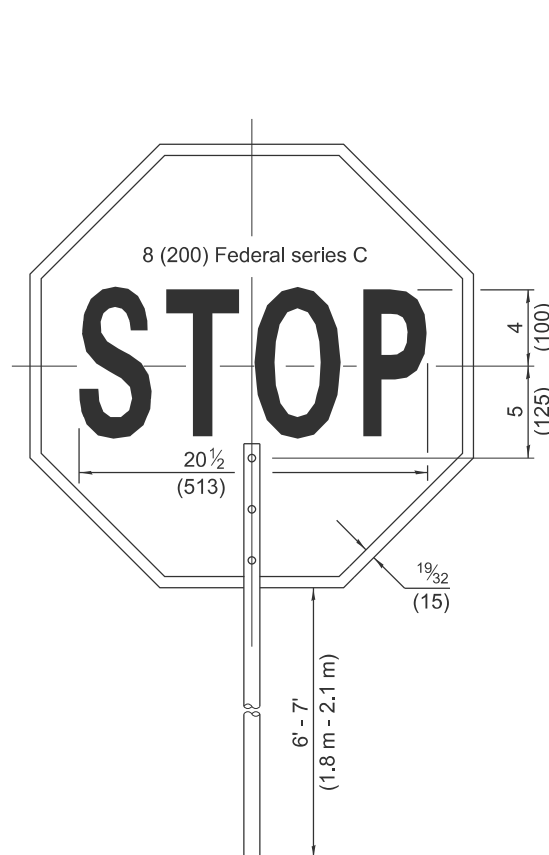

FRONT SIDE

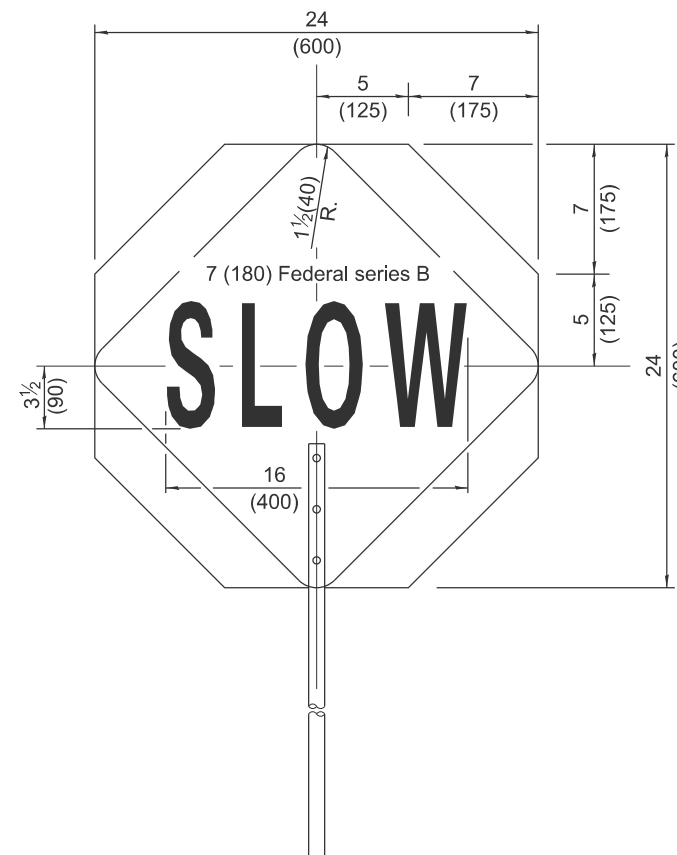

REVERSE SIDE

FLAGGER TRAFFIC CONTROL SIGN

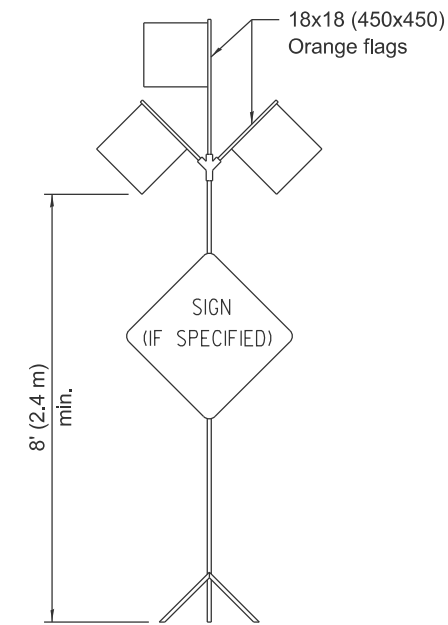

HIGH LEVEL WARNING DEVICE



G20-1104(0)-6036



G20-1105(0)-6024

This signing is required for all projects 2 miles (3200 m) or more in length.

ROAD CONSTRUCTION NEXT X MILES sign shall be placed 500' (150 m) in advance of project limits.

END CONSTRUCTION sign shall be erected at the end of the job unless another job is within 2 miles (3200 m).

Dual sign displays shall be utilized on multi-lane highways.

WORK LIMIT SIGNING

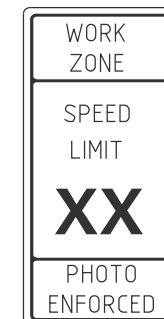

W21-1115(0)-3618

R2-1-3648

R10-1108p-3618 ****



R2-1106p-3618

Sign assembly as shown on Standards or as allowed by District Operations.

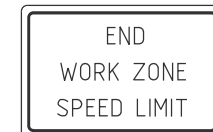

G20-1103-6036

This sign shall be used when the above sign assembly is used.

HIGHWAY CONSTRUCTION SPEED ZONE SIGNS

**** R10-1108p shall only be used along roadways under the jurisdiction of the State.

TRAFFIC CONTROL DEVICES

(Sheet 2 of 3)

STANDARD 701901-11

Illinois Department of Transportation

APPROVED January 1, 2026
ENGINEER OF SAFETY PROG. AND ENGINEERING

APPROVED January 1, 2026
ENGINEER OF DESIGN AND ENVIRONMENT

ISSUED 1-1-13

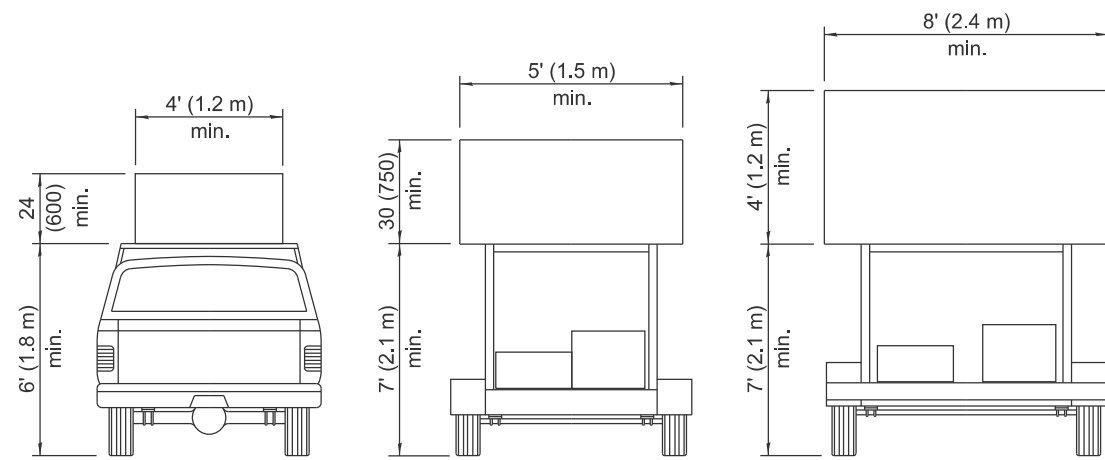

**TYPE A
ROOF
MOUNTED**

**TYPE B
ROOF OR TRAILER
MOUNTED**

**TYPE C
TRAILER
MOUNTED**

ARROW BOARDS



MULTI-LANE HIGHWAYS

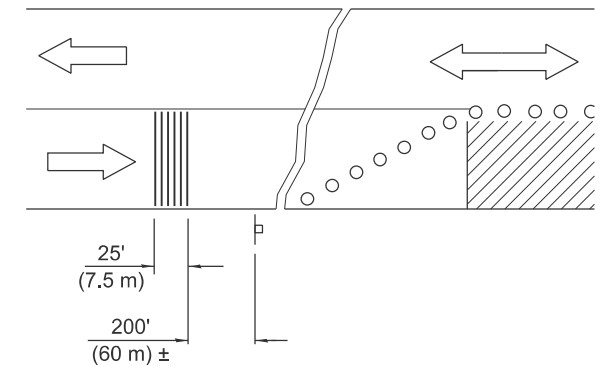

TWO-LANE HIGHWAYS

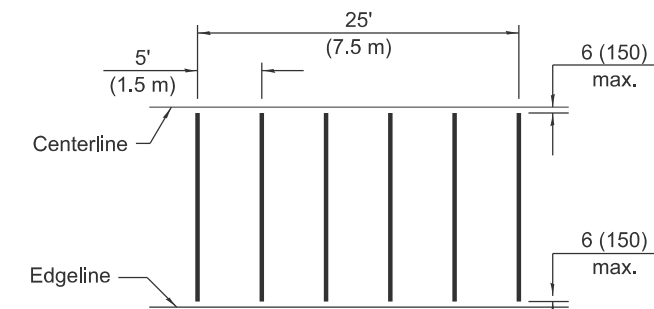

TYPICAL INSTALLATION

TEMPORARY RUMBLE STRIPS

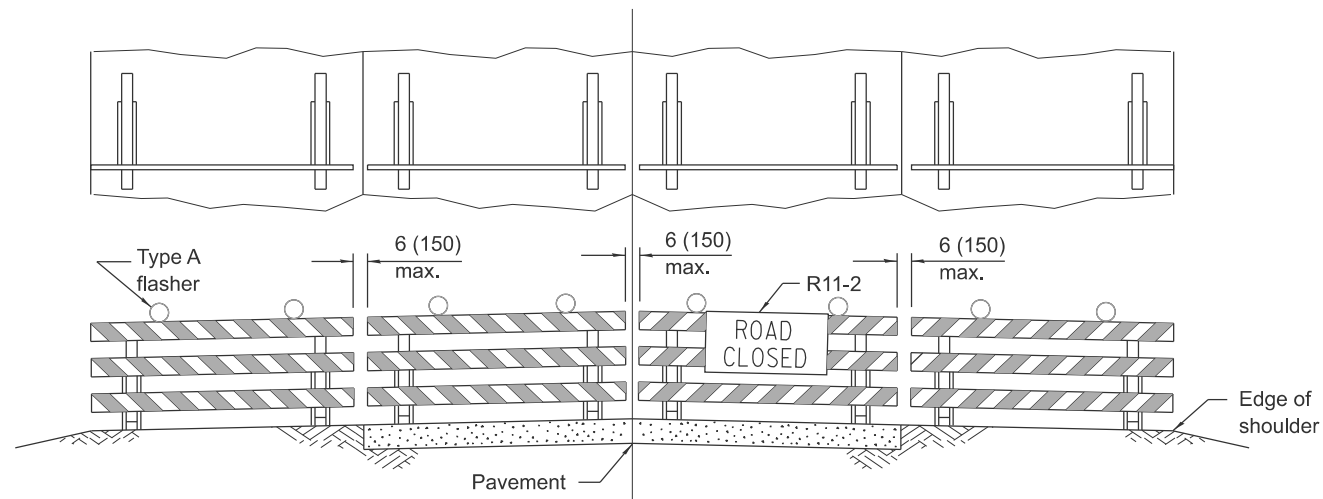

ROAD CLOSED TO ALL TRAFFIC

Reflectorized striping may be omitted on the back side of the barricades.

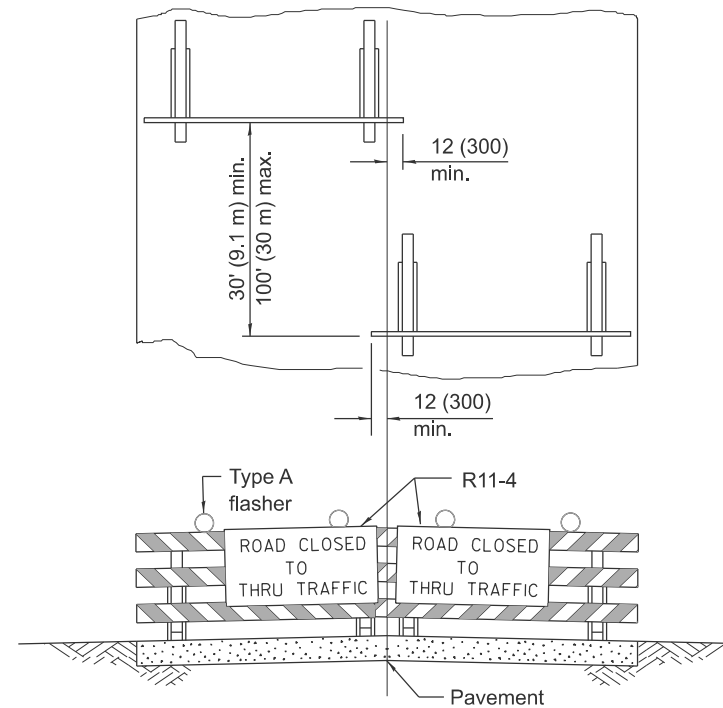

ROAD CLOSED TO THRU TRAFFIC

Reflectorized striping shall appear on both sides of the barricades.

**TYPICAL APPLICATIONS OF
TYPE III BARRICADES CLOSING A ROAD**

If a Type III barricade with an attached sign panel which meets NCHRP 350 or MASH is not available, the sign may be mounted on an NCHRP 350 or MASH temporary sign support directly in front of the barricade.

Illinois Department of Transportation

APPROVED January 1, 2026

ENGINEER OF SAFETY PROG. AND ENGINEERING

APPROVED January 1, 2026

ENGINEER OF DESIGN AND ENVIRONMENT

ISSUED 1-1-13

**TRAFFIC CONTROL
DEVICES**

(Sheet 3 of 3)

STANDARD 701901-11

EAST NORTH AVE.

